





CONFIGURATION

Multi-function Instrument	High Efficiency AC Drive Motor
Lifting/Steering Computer Controlled	Gear Pump with Low Noise
Pedal Rubber	Energy Efficient Dynamic Signal
Standard Battery	Load Sensing Hydraulic System
Emergency Power Off	Top Rain Shelter
Full Set LED Lamps	Charging Indicator
Reversing Buzzer	Electric Horn
Standard Seat	Wide-angle Rearview Mirror
Full-hydraulic Power Steering	Traction Pin
Wide Field Mast	Tool Box
Low Resistance Tires	Standard Forks
Two Piece Multiplex Valve	Lifting and Tilting Joysticks

OPTIONAL included

Cabin	Large Capacity Battery
Cold A/C	Widen and Lengthen Backrest
Warm-air Blower	Widen Fork Frame
Suspension Seat 	Protective Net
Lifting Potentiometer	Electric Fan
Battery Charger 	Reversing Handrail Horn
Lateral Pull Battery(1-2.5T)	Corner Positioner
Lateral Shovel Battery(3-3.5T)	Reversing Radar
Lithium Battery	Lengthen Fork Jacket
Rotate Buzzer Beacon	Tilting Cylinder Sleeve
Rear Working Lamp	Steering Cylinder Sleeve
Working Warning Light 	Custom Colors
Green Solid Tires	Multiple Work Attachments
Solid Tires 	

PRODUCT FEATURES

Attractive Appearance
Vehicle appearance is designed by professional industrial design methods. Artistic and Strengthful.

Strong Stability
Battery is sinking designed to ensure vehicle stability. Integral type axle & gear box and short front overhang improve vehicle longitudinal stability. Overhead rear axle improves vehicle lateral stability.

Operating Comfort
Short diameter steering wheel and right-hand joysticks reduce operator's arm fatigue. Sinking designed tilting cylinders increase operator's foot space and safety. Spines tooth type hand brake conforms the motion of arm. Comfortable control.

Energy Efficiency
Transmission system and electric motor are professional matching designed. Battery life is prolonged by 30 minutes. Automatic turning slowdown function is optional. Equipped with LED light, energy and efficient.

Well-adapted
Lateral pull battery is optional. Adapt to different working environment.

Convenient Maintenance
Special locking structure and side panel structure designed makes battery maintenance very convenient.

The following blank can be used for notes or comments.

**For more information on Lonking products,
Please contact our local agent:**

Lonking, Lonking LG Series and their respective logos, as well as corporate identity in this leaflet are trademarks of Lonking Holdings Ltd., and may not be used without written permission.
2020/04

Specifications and design are subject to change without prior notice.
Machines shown may not include optional accessories.

Lonking 龙工

LG15/18/20/25/30/35BVI BALANCEWEIGHT TYPE FORKLIFT TRUCK WITH BATTERY Efficiency Rules the Future



- In motion controller
- Solid tires
- Mast: 3 stage 4.8m(15ft)
- Suspension seat
- Cascade sideshifter
- Full hydraulic power steering



PayaTech Inc.

Tel: +1 (778) 680-4140

info@payatech.ca

www.payatech.ca

	LG15BVI	LG18BVI	LG20BVI	LG25BVI	LG30BVI	LG35BVI
Rated Capacity (kg)/(lb)	1500/3300	1800/4000	2000/4400	2500/5500	3000/6600	3500/7700
Load Center (mm)/(in)	500/20	500/20	500/20	500/20	500/20	500/20
Power Type			Electric (AC)			

OVERALL SPECIFICATIONS

Type	No.	Item	Code	Unit	Data						
Identification	1.01	Manufacturer			LONKING						
	1.02	Model			LG15BVI	LG18BVI	LG20BVI	LG25BVI	LG30BVI	LG35BVI	
	1.03	Power type			Electric (AC)						
	1.04	Rated capacity	Q	kg	1500	1800	2000	2500	3000	3500	
	1.05	Load center	J	mm	500	500	500	500	500	500	
Dimensions	2.01	STD Max height (with backrest)		mm	4030	4030	4042	4042	4210	4210	
	2.02	STD Max lifting height	h1	mm	3000	3000	3000	3000	3000	3000	
	2.03	Overhead guard height	h4	mm	2140	2140	2148	2148	2201	2201	
	2.04	Overall length (with fork)	L1	mm	2982	2982	3310	3320	3550	3590	
	2.05	Wheelbase	L2	mm	1380	1380	1550	1550	1685	1685	
	2.06	Front overhang	L3	mm	392	392	434	434	488	488	
	2.07	Rear overhang	L4	mm	290	290	300	310	308	348	
	2.08	Min.ground clearance (Frame/Mast)	m1/m2	mm	90/95	90/95	115/110	115/110	125/135	125/135	
	2.09	Overall width	W1	mm	1086	1086	1185	1185	1238	1238	
	2.10	Adjusting range of fork (outside)		mm	210-960	210-960	250-1030	250-1030	260-1055	260-1055	
	2.11	STD Fork size (L5*W*T)		mm	920×100×35		1070×120×40			1070×125×50	
	2.12	Front wheel tread	S	mm	910	910	960	960	1000	1000	
	2.13	Rear wheel tread	P	mm	920	920	950	950	950	950	
	2.14	Min.turning radius	R1	mm	1800	1800	2000	2020	2210	2270	
	2.15	Min aisle width for pallet 1000×1200,crossways		mm	3409	3409	3635	3655	3968	4028	
	2.16	Min aisle width for pallet 800×1200,lengthways		mm	3591	3591	3738	3758	4098	4158	
Tires	3.01	Wheels number, front/rear (X=driven wheels)			X=2/2						
	3.02	Tires type			Pneumatic						
	3.03	Tires size, front			6.00-9-10PR		23×9-10-16PR		28×9-15-14PR		
	3.04	Tires size, rear			16×6-8-10PR		18×7-8-14PR		18×7-8-14PR		
Other Details	4.01	Max.traveling speed, loaded/unloaded (STD)		km/h	13/12		13/12		13/12		
		Max.traveling speed, loaded/unloaded (High)		km/h	13/12		13/12		15.5/15		
		Max.traveling speed, loaded/unloaded (Li-ion)		km/h	15/14		15/14		15.5/15		
	4.02	Max.lifting speed, loaded/unloaded (STD)		mm/s	500/350	500/350	430/300	430/300	400/240	370/220	
		Max.lifting speed, loaded/unloaded (High)		mm/s	500/350	500/350	430/300	430/300	460/340	450/325	
		Max.lifting speed, loaded/unloaded (Li-ion)		mm/s	500/350	500/350	430/300	430/300	460/340	450/325	
	4.03	Lowering speed, loaded/unloaded		mm/s	Loaded≤600/Unloaded≥300						
	4.04	Max.gradient, loaded (STD)		%	15	15	15	15	13	12	
		Max.gradient, loaded (High/Li-ion)		%	20	20	20	20	15	15	
	4.05	STD operating weight (with oil & water)		kg	3050	3270	3950	4100	4740	5160	
4.06	Axles loading,front/rear (loaded)		kg	4008/542	4430/640	5152/798	6000/600	7190/550	8010/650		
4.07	Axles loading,front/rear (unloaded)		kg	1555/1495	1615/1655	1936/2014	2000/2100	2380/2360	2360/2800		
4.08	Drive motor (STD)		kw	8.2	8.2	11.5		11	11		
	Drive motor (High/Li-ion)		kw	8.2	8.2	11.5	11.5	16.6	16.6		
4.09	Lift motor (STD)		kw	10.6		15	15	15	15		
	Lift motor (High/Li-ion)		kw	10.6		15	15	13.5	13.5		
4.10	Controller			Inmotion	Inmotion	Inmotion	Inmotion	Inmotion	Inmotion		
4.11	Lead-acid Battery votage/capacity		V/Ah	48/420		48/600		48/700-80/480 (High)			
	Li-ion Battery votage/capacity		V/Ah	48/200		48/400		80/300			

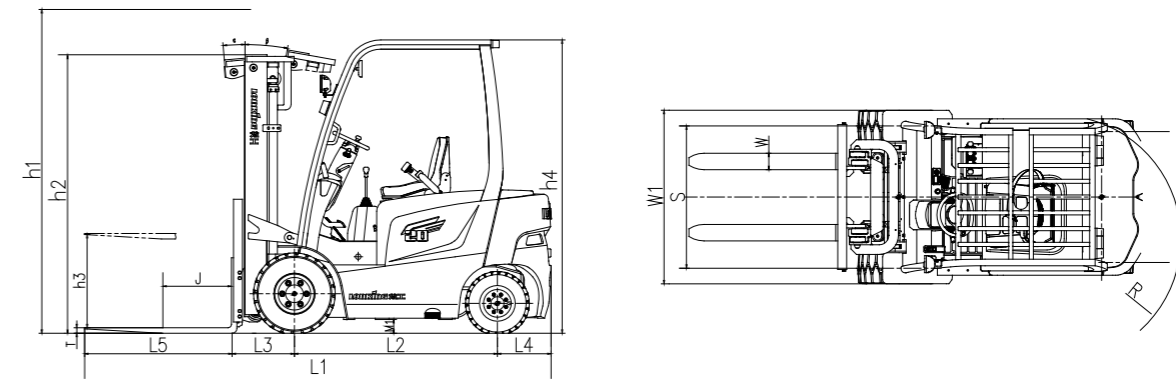

MAST SPECIFICATIONS

Mast Model	h1 Max Lifting Height(mm)	Load Capacity (J=500mm) (kg)						h2 Lowered Mast Height (mm)				h3 Free Lifting Height, without backrest (mm)				Mast tilt α/β (°)	
		1.5T	1.8T	2T	2.5T	3T	3.5T	1.5-1.8T	2-2.5T	3T	3.5T	1.5-1.8T	2-2.5T	3T	3.5T	1.5-2.5T	3-3.5T
M200	2000	1500	1750	2000	2500	3000	3500	1485	1495	1570	1680	155	140	145	150	6/8	6/10
M230	2300	/	/	/	/	/	/	/	/	/	/	/	/	/	/	/	/
M250	2500	1500	1750	2000	2500	3000	3500	1735	1745	1820	1930	155	140	145	150	6/8	6/10
M270	2700	1500	1750	2000	2500	3000	3500	1835	1845	1920	2030	155	140	145	150	6/8	6/10
M275	2750	/	/	/	/	/	/	/	/	/	/	/	/	/	/	/	/
M300	3000	1500	1750	2000	2500	3000	3500	1985	1995	2070	2180	155	140	145	150	6/8	6/10
M330	3300	1500	1750	2000	2500	3000	3500	2135	2145	2220	2330	155	140	145	150	6/8	6/10
M350	3500	1500	1750	2000	2500	3000	3500	2235	2245	2320	2430	155	140	145	150	6/8	6/10
M370	3700	1500	1750	2000	2500	3000	3400	2335	2345	2420	2530	155	140	145	150	6/8	6/6
M375	3750	/	/	/	/	/	/	/	/	/	/	/	/	/	/	/	/
M400	4000	1500	1750	2000	2500	2950	3350	2535	2545	2620	2730	155	140	145	150	6/5	6/6
M425	4250	/	/	/	1500	/	/	2660	2670	2745	2855	155	140	145	150	6/5	6/6
M450	4500	1400	1600	1900	2300	2750	3100	2785	2795	2870	2980	155	140	145	150	6/5	6/6
M475	4750	1400	1600	1850	2100	2600*2950	2950	2910	2920	2995	3105	155	140	145	150	6/5	6/6
M500	5000	1200	1350	1800	1950	2400*2850	2650*2800	3035	3045	3120	3230	155	140	145	150	6/5	6/6
M550	5500	1100	1200	1400	1550	2250*2400	2500*2600	3335	3345	3420	3530	155	140	145	150	3/3	3/6
M600	6000	800	850	950	1100	1500*2200	1550*2400	3585	3595	3670	3780	155	140	145	150	3/3	3/6

Note:*** means capacity of double front wheels.

Mast Model	h1 Max Lifting Height(mm)	Load Capacity (J=500mm) (kg)						h2 Lowered Mast Height (mm)				h3 Free Lifting Height, without backrest (mm)				Mast tilt α/β (°)	
		1.5T	1.8T	2T	2.5T	3T	3.5T	1.5-1.8T	2-2.5T	3T	3.5T	1.5-1.8T	2-2.5T	3T	3.5T	1.5-2.5T	3-3.5T
ZM200	2000	1500	1750	2000	2500	3000	3500	1485	1495	1570	1680	864	861	851	856	6/8	6/10
ZM250	2500	1500	1750	2000	2500	3000	3500	1735	1745	1820	1930	1114	1111	1101	1106	6/8	6/10
ZM270	2700	/	/	2000	2500	3000	3500	/	1845	1920	2030	/	1211	1201	1206	6/8	6/10
ZM275	2750	1500	1750	/	/	/	/	1860	/	/	/	1239	/	/	/	6/8	/
ZM300	3000	1500	1750	2000	2500	3000	3500	1985	1995	2070	2180	1364	1361	1351	1356	6/8	6/10
ZM330	3300	1500	1750	2000	2500	3000	3500	2135	2145	2220	2330	1514	1511	1501	1506	6/8	6/10
ZM350	3500	1500	1750	2000	2500	3000	3500	2235	2245	2320	2430	1614	1611	1601	1606	6/8	6/10
ZM370	3700	/	/	2000	2500	3000	3400	/	2345	2420	2530	/	1711	1701	1706	6/8	6/6
ZM375	3750	1500	1750	/	/	/	/	2360	/	/	/	1739	/	/	/	6/8	/
ZM400	4000	1500	1750	2000	2500	2950	3350	2535	2545	2620	2730	1914	1911	1901	1906	6/5	6/6
ZM425	4250	/	/	2000	2500	/	/	2670	/	/	/	2036	/	/	/	6/5	/
ZM450	4500	1400	1600	1900	2300	2750	3100	2785	2795	2870	2980	2164	2161	2151	2156	6/5	6/6
ZM475	4750	/	/	1850	2100	/	/	2920	/	/	/	2286	/	/	/	6/5	/
ZM500	5000	/	/	1800	1950*2050	/	/	3045	/	/	/	2411	/	/	/	6/5	/
ZM550	5500	/	/	1400	1550*1950	/	/	3345	/	/	/	2711	/	/	/	3/3	/
ZM600	6000	/	/	950*1500	1100*1800	/	/	3595	/	/	/	2961	/	/	/	3/3	/

Note:*** means capacity of double front wheels. 1.5-1.8T free lifting height reduces 384mm with backrest. 2-2.5T free lifting height reduces 378mm with backrest. 3-3.5T free lifting height reduces 346mm with backrest.

Mast Model	h1 Max Lifting Height(mm)	Load Capacity (J=500mm) (kg)						h2 Lowered Mast Height (mm)				h3 Free Lifting Height, without backrest (mm)				Mast tilt α/β (°)	
		1.5T	1.8T	2T	2.5T	3T	3.5T	1.5-1.8T	2-2.5T	3T	3.5T	1.5-1.8T	2-2.5T	3T	3.5T	1.5-2.5T	3-3.5T
ZSM320	/	/	/	/	/	/	/	/	/	/	/	/	/	/	/	/	/
ZSM360	3600	1500	1750	2000	2500	2900	3300	1780	1795	1935	1935	1259	1245	1260	1265	6/8	6/6
ZSM400	4000	1500	1750	2000	2500	2900	3250	1918	1920	2070	2070	1397	1370	1395	1400	6/5	6/6
ZSM435	4350	1450	1650	2000	2450	2800	2900	2030	2045	2185	2185	1509	1495	1510	1515	6/5	6/6
ZSM450	4500	1400	1600	2000	2300	2700	2800	2080	2095	2235	2235	1559	1545	1560	1565	6/5	6/6
ZSM470	4700	1350	1550	2000	2200	2600	2700	2150	2160	2300	2300	1629	1610	1625	1630	6/5	6/6
ZSM480	4800	1300	1500	1900	2050	2500	2600	2180	2195	2335	2335	1659	1645	1660	1665	6/5	6/6
ZSM500	5000	1200	1300	1800	1950*2050	2400*2500	2450	2280	2295	2430	2430	1759	1745	1755	1760	6/5	6/6
ZSM540	5400	1000	1050	1400	1550*1950	2250*2450	2300	2405	2420	2560	2560	1884	1870	1885	1890	3/3	3/6
ZSM600	6000	750	750	950*1500	1100*1800	1500*2100	1550*2300	2630	2645	2785	2785	2109	2095	2110	2115	3/3	3/6